

FLOATING FLOOR MOUNT

Series: TS-80



- Protrusions limit movement and grips unit to floor.
- X-shape base improves elasticity of the system.
- Excellent soundproofing performance.
- Greater performance compared to EPDM and other polymers.
- Optimal load: 35kg to 400kg per mount.
- Suited for acoustic floors and inertia bases.

MATERIAL

- Polymer Body: Kraiburg TPE

Part Number	Optimal Load per mount (kg)	Material Properties
TS-80 V 150	35 ~ 200	PDF
TS-80 A 280	150 ~ 280	PDF
TS-80 R 400	250 ~ 400	PDF

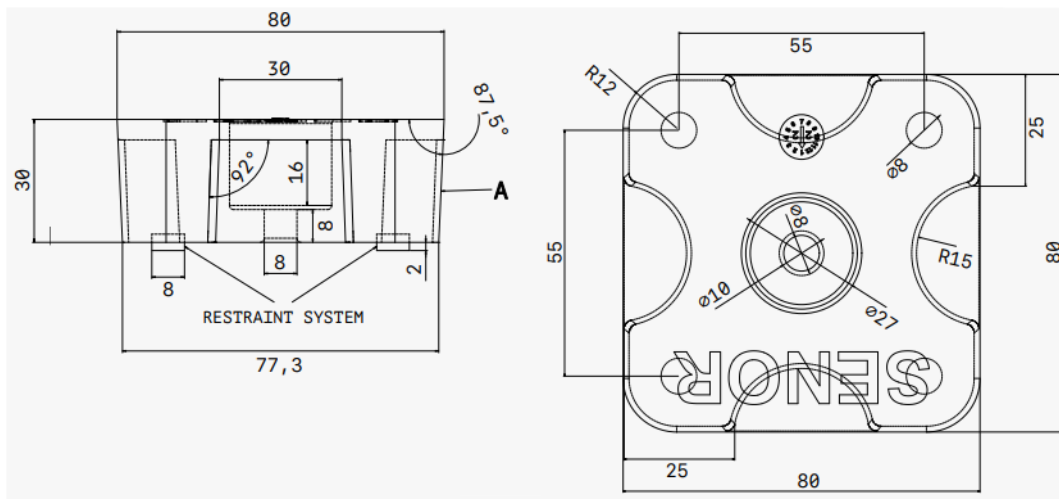

- [ENGINEERING DRAWING](#)
- [ACOUSTIC TEST REPORT](#)
- [INSTALLATION GUIDE](#)

APPLICATION EXAMPLES

